

Quadruped Auto

3-D Models

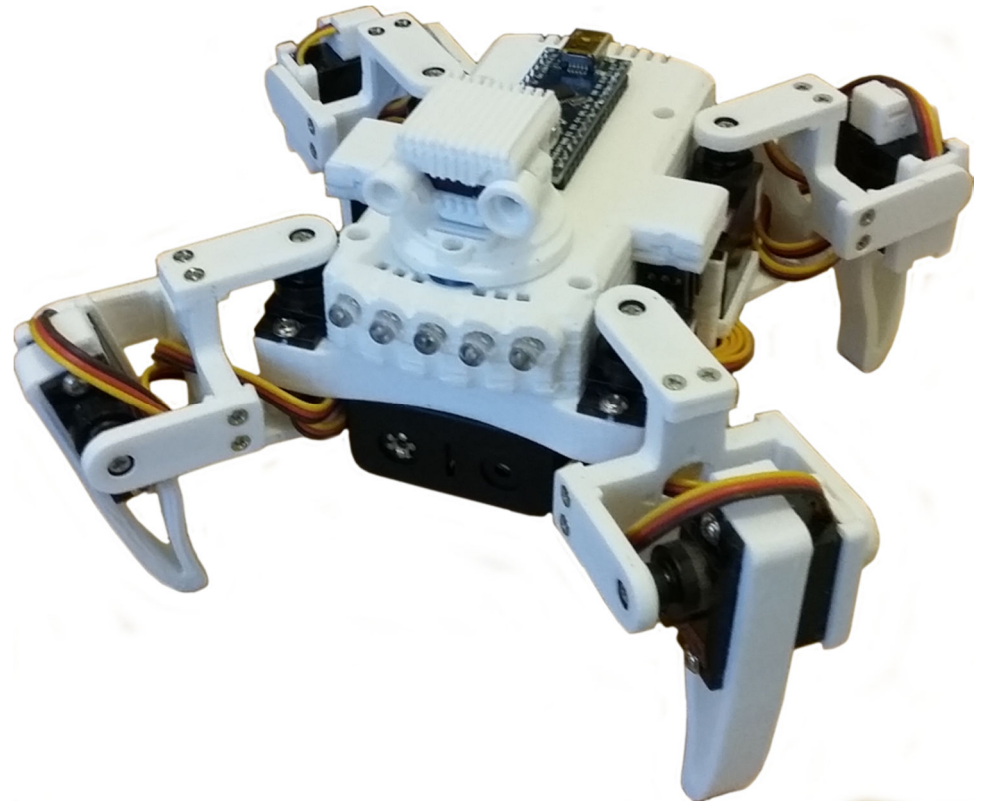

These 3-D exploded views of the assembly should enable you to identify all of the parts. Multiple parts are shown as N x.

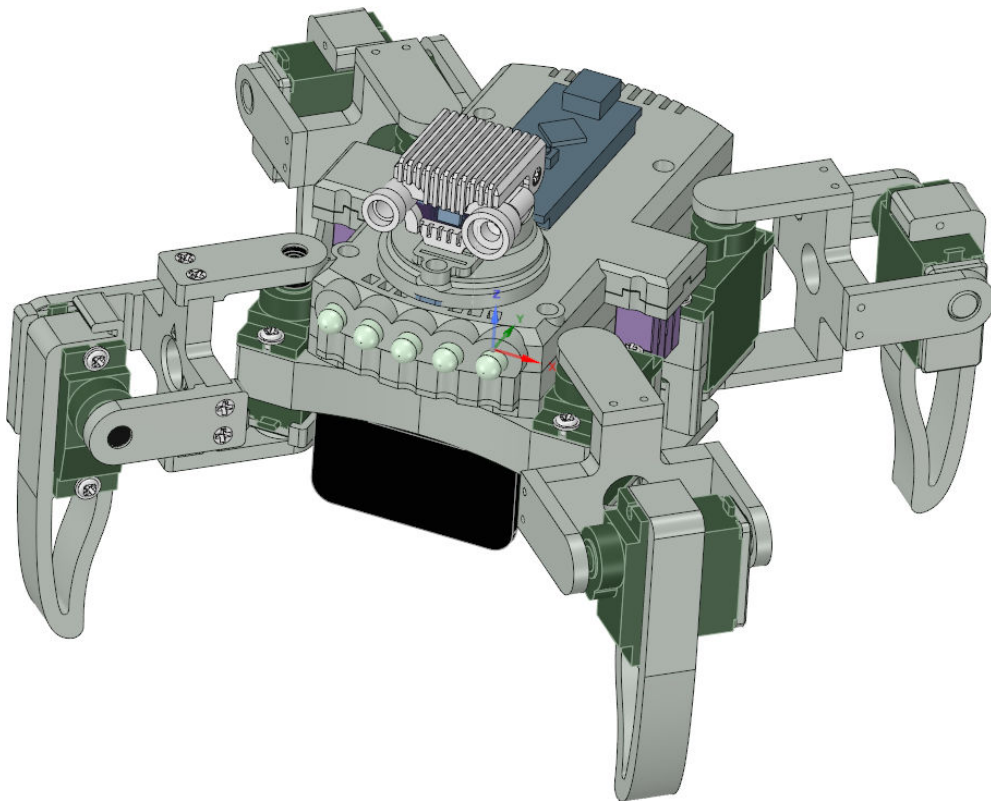
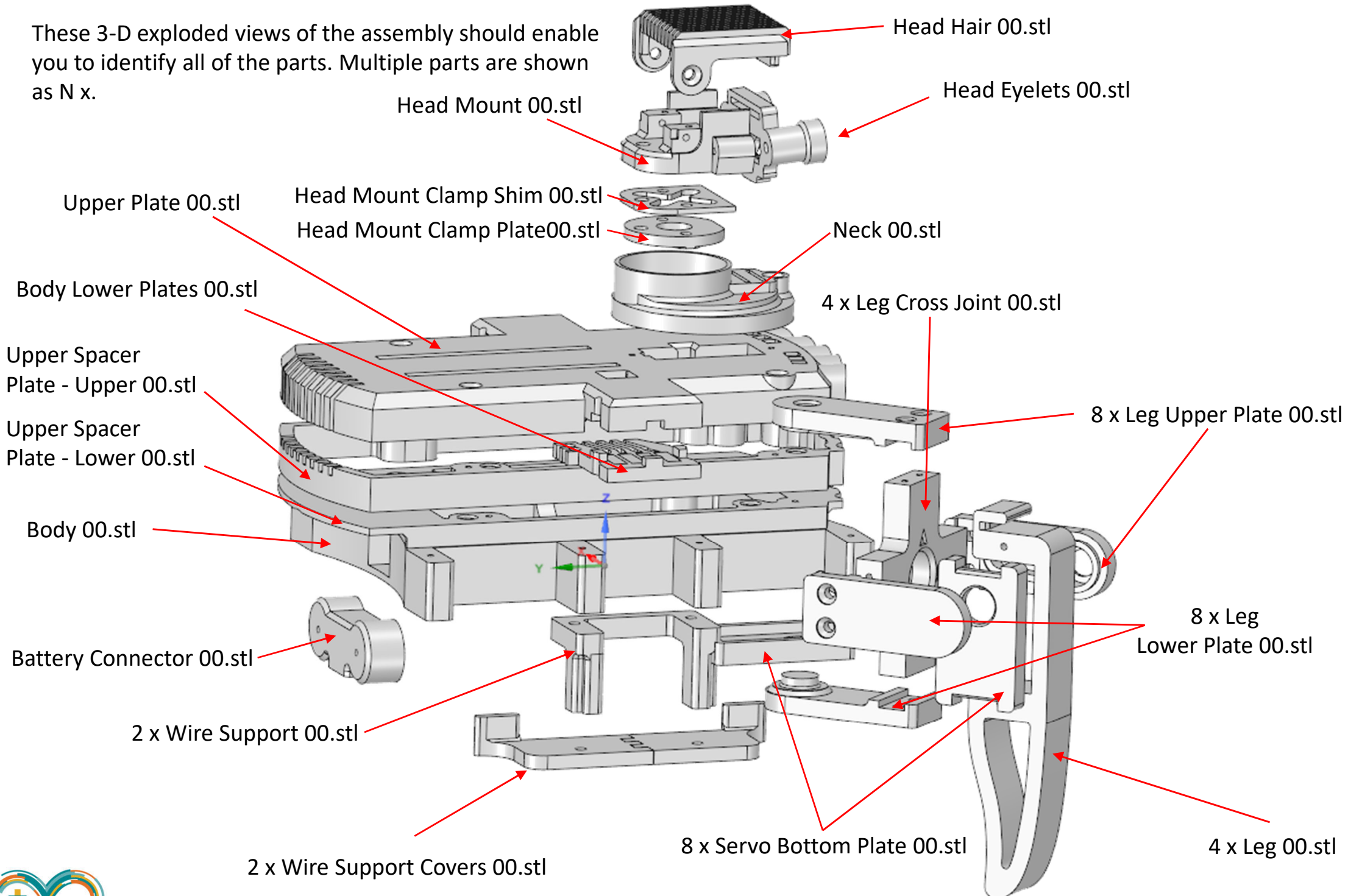

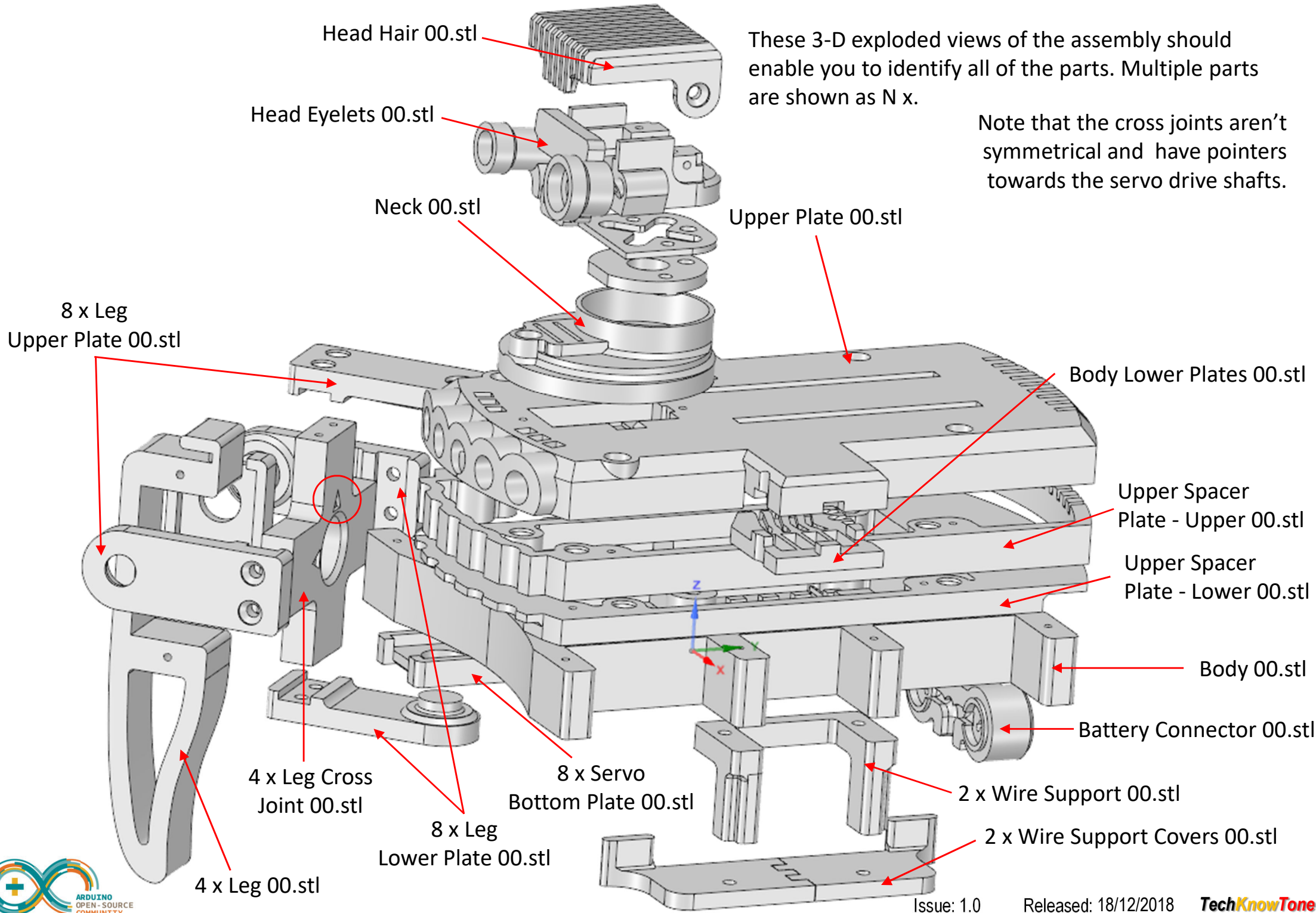

These 3-D exploded views of the stand assembly should enable you to identify all of the parts. Multiple parts are shown as N x.

2 x Stand Link 00.stl

2x Stand End Plate.stl

2x Stand Plate 00.stl

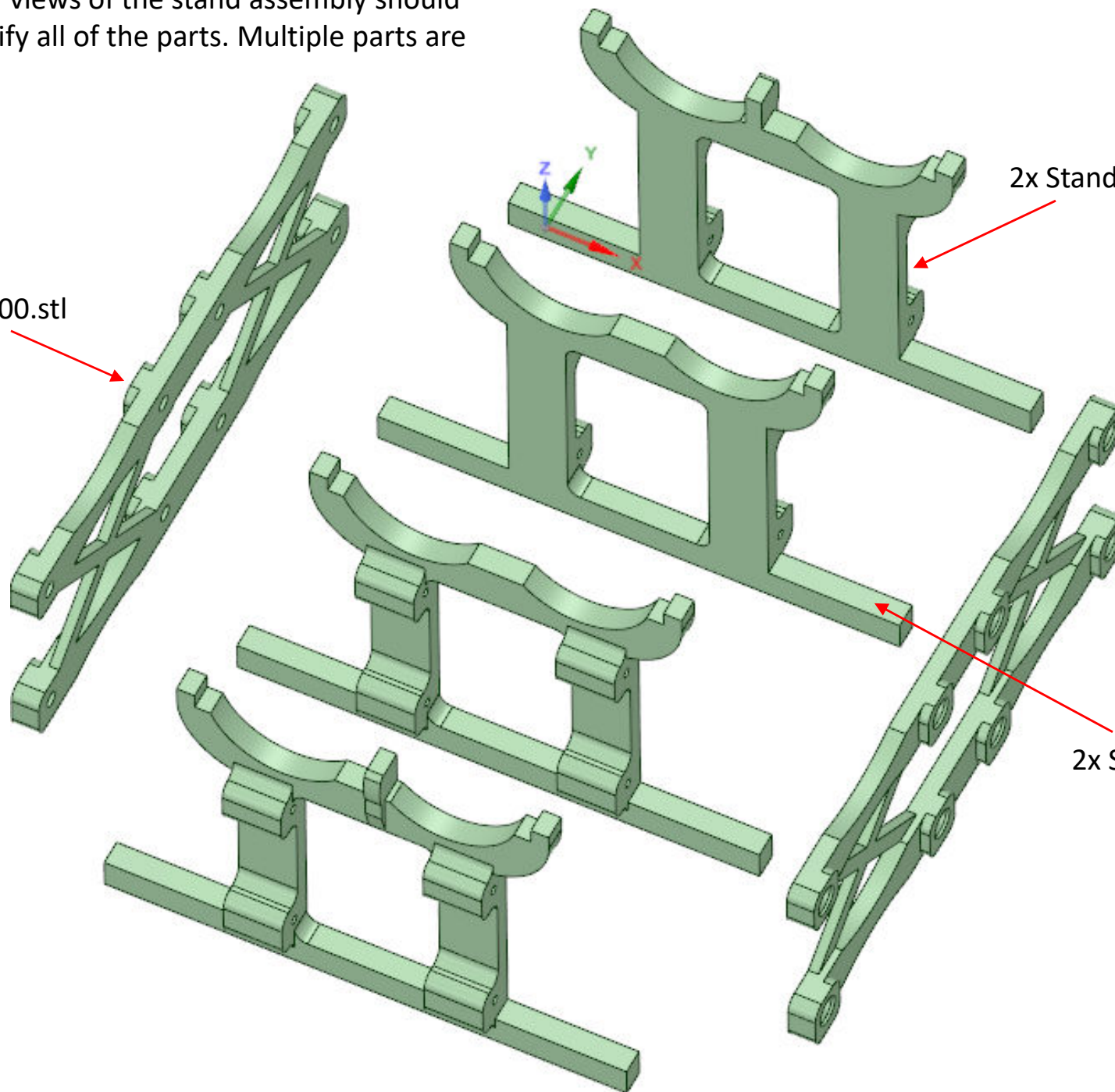

These are 3-D exploded views of the soldering stand assembly, which supports the robot and protects its head whilst the robot is upturned for soldering. Making the process much easier to do.

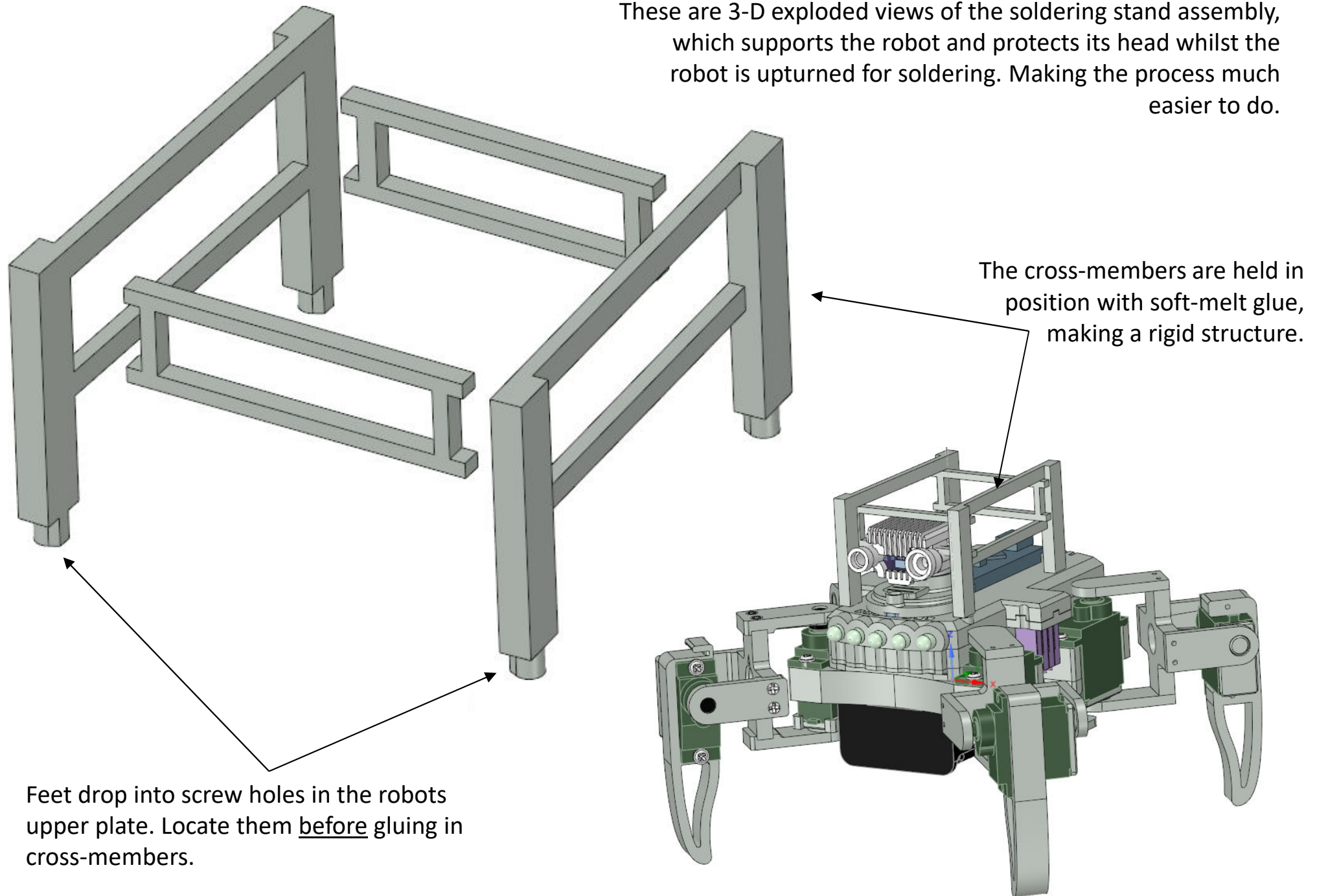

The cross-members are held in position with soft-melt glue, making a rigid structure.

Feet drop into screw holes in the robots upper plate. Locate them before gluing in cross-members.